

New application techniques and construction methods for light earth in timber architecture

In today's search for sustainable, healthy, environmentally-friendly and resource-efficient ways of building, new combinations of wood and earth offer a contemporary alternative. The surplus in sustainable wood production has given rise to a revival of timber construction, and in turn opened up the possibility of revisiting traditional methods of timber-frame construction and earth infill using modern means, for example in combination with computer-milled, screw-assembled modern timber skeleton or panel frame constructions. Earth is a supple, moisture-absorbing material that holds neighbouring materials dry making it an ideal partner for timber construction. The wood structure bears the load and stiffens the construction, while the spaces between them are filled with "soft" non-loadbearing materials. Earth building materials are ideal as they can act as heat retainers and heat buffers (passive heat retention in winter, night-time cooling in summer), as noise and fire insulation, and as the wall surface and plaster base. Even relatively slender constructions can significantly improve the quality of the indoor environment and room climate. External construction elements are traditionally clad with an additional layer of insulation. However, in combination with capillary-conductive natural fibre insulation materials, it is also possible to achieve good moisture protection using simple constructions with internal insulation. By exploiting the sorptive, moisture transporting properties of earth building materials, there is no need for a vapour barrier. Such constructions likewise obviate the need for plywood sheathing or dedicated installation layers, not to mention sealing tape with its limited lifespan. One of the major advantages of timber construction are its thin wall thicknesses, making it possible to maximise the available floor area. Most modern rigid building materials are stronger than they actually need to be and require energy-intensive shredding prior to recycling. Earth and timber constructions on

the other hand are easy to disassemble, convert or extend without excessive noise and the majority of the materials are recyclable. Moreover houses made of timber and earth need not be expensive and offer numerous opportunities for self-building.

Alongside the various existing infill techniques using light earth – wet insertion in formwork or as a wall lining, and dry infill as light earth brick masonry or panel blockwork, or as a stacked dry wall lining – another new and interesting alternative is the manual application of malleable straw-clay onto a supporting lathwork.

This technique builds on the historical technique of straw-clay application onto a wattle backing but employs light earth as this is easier to prepare than heavy straw-clay mixtures and of a better quality, firmness and elasticity due to its high fibre content. It also provides an excellent substrate for subsequent plastering. Working with a malleable material also obviates the need for formwork, and at the same time does not require the laborious construction of a woven wattle backing. The technique can be used for both internal and external walls, as well as for ceilings, roof inclines and as a backing for light earth or fibrous clay undercoat plasters. Both the preparation of the light earth mass as well as its application is simple and straightforward and does not require special tools or machinery making it easy to undertake oneself.

Learning from historical straw-clay infill

The term straw-clay or fibre-clay denotes fibrous clay mixtures with a dry bulk density of $> 1200 \text{ kg/m}^3$. Light earth therefore denotes all earth building materials with a bulk density of $< 1200 \text{ kg/m}^3$. Our own tests of historical straw-clay mixtures have revealed that these were often of a lower density and would today be classed as light earth mixtures. The propor-



Abb. 1 Historical straw-clay panel infill material with a high straw content, 1200 kg/m³, Darmstadt, 18th century



02 Section through historical straw-clay panel infill, showing wrapping technique, Limburg, 17th century

tion of straw was greater and that of earth less than originally supposed. Indeed, some historical accounts describe the need to mix in “as much straw as possible” with the manure fork so that it resembles stable manure, and that simply treading the earth mass and adding “some straw” often produced a heavy, insufficiently stabilised mass. But the material density is not the only difference: the application technique and details of the new method differ from common historical methods in many respects.

Example 1: As part of the conversion and renovation of the Gotischen Haus in Limburg, we were able to investigate the structure of five infill panels from different epochs that date as far back as the 13th century (Volhard 2010). Of particular interest were Panel 4 from the 17th century (figure 2) which was firmly wrapped with straw-clay and Panel 3 from the 16th century in which the straw-clay was simply hung over the wattle. The earth here must have been fairly malleable and viscous to be so workable, and applied in very large sections. The surfaces were evened off with a board or plank, through a combination of patting down and smoothing to compress the mass (the German term “Lehmschlag” may refer to this process of patting down).

Example 2: Examples of straw-clay construction in northern Europe, for example in Normandy (Torchis), show entirely different, almost modern-looking constructions and application methods. Here too there are a number of quite different techniques of varying quality, which for the most part can be attrib-

uted to the proportion of straw in the mixture: a high proportion of straw made for a better quality plaster with good plaster adhesion not to mention the thermal insulation. The panels with a lower proportion of straw exhibited cracking through contraction as well as gaps at the panel edges where it meets the timber. As a consequence they are more susceptible to frost and entire sections had fallen out where the protective topcoat was no longer intact. However, the primary aspect that sets this construction method apart is the use of continuous horizontal laths in place of a wattle between the vertical timber members. This was affixed to supporting laths and sometimes directly to the timber structure and could be placed on the inner or outer of the wall, sometimes even on the inner and outer faces. Strips of straw-clay were laid saddle-like over the laths until the desired thickness had been achieved and then smoothed down. Where this was applied on both sides of the wall, the cavity between the two layers served as an insulating air layer and was sometimes filled with straw-clay (for details see Volhard 2016).

Example 3: Historical straw-clay plaster can be found used as an undercoat for lime plaster on the inner face of half-timbered wall constructions where it acts as an insulating, windproof layer. Applied at a thickness of up to 50 mm, the plaster covers over irregularities on the inner face of half-timbered surfaces, or was used as a thin levelling plaster. Straw-clay undercoat plasters have also been used to plaster over rammed earth wall surfaces, which lime plasters do not adhere to well. The high straw content has an insulat-

ing effect, making straw-clay surfaces warm to the touch, which helped improve the thermal comfort of the stove-heated interiors of the day, where heat came primarily from a radiative source. Our investigations showed that these plasters rarely contained any sand, but were prepared with significant quantities of straw chipping or other fibres, sometimes also with long stems of straw to create a tangled mat of plaster mass stable enough to be spread across entire wall surfaces including timber elements before plastering over with a lime plaster. On wider timber members as well as around ceiling joists and beams, the mass was additionally fixed in place with nailed-on split willow rods.

New construction methods using manual application techniques

The study of historical techniques shows that the quality of such plasters was determined not only by the high clay content but also the very high straw or fibre content. An interesting and obvious extension of this idea would be to prepare such heavy mixtures in the manner of light earth by dipping or spraying with a liquid clay slurry and then applying them directly while still soft and malleable. That would open up new possibilities of applying earth, of simplifying the construction, speeding up the process of application, and improving the overall quality (Volhard 2016).

Manual application onto wall surfaces

A sensible wall thickness for an earth shell is around 12–14 cm. This was common in most half-timbered constructions and also facilitates better drying. Modern timber constructions differ from their historical predecessors in that there are no horizontal rails and infill panels with stakes or wattle. In their place we apply a screen of continuous horizontal laths that is quickly and easily nailed or screwed to the vertical timber posts of an material-efficient timber frame or panel construction. The distance between posts depends on the cross-section of the lath (e.g. 3 x 3 cm) but the interval between loadbearing posts can be increased if additional interim posts for supporting the laths are introduced. That can help reduce the quantity of high-quality structural timber required. The timber structure is generally covered by an unbroken layer of earth and then faced with a protective layer of lime plaster. Depending on the thickness of the layer of earth mass, the laths can be spaced around 12 cm apart (i.e. 8 laths per metre). Uncut straw used directly from the straw bale is generally long enough

to cover over such lath spacings. In Normandy, lath spacings can be as much as 30 cm. In accordance with the lath spacing, suitably large sections of earth are applied to the supporting structure. Using a hook or garden fork, a portion of the mass is pulled out, brought into shape and then laid saddle-like over the laths next to and over one another. The resulting wall surface is then levelled with a board and smoothed over, filling any remaining holes or irregularities with the same material. If constructing two skins, each layer can be thinner (approx. 5–8 cm) and the cavity between them filled with a suitable earth fill material or other cavity insulation material. Thinner wall thicknesses can have smaller lath spacings and cross-sections, and using thin battens (12 x 24 mm) it is possible to construct very thin walls of approx. 4 cm thick (figure 10).

External walls with insulation layer

In both new buildings as well as renovation projects, the advantage of internal insulation (or cavity insulation) is the ability to exploit passive heat gain through solar radiation and outdoor warmth rather than keeping it out with external insulation. The resulting reduction of the mean temperature difference between indoor and outdoor wall surface temperatures reduces energy consumption. The commonly cited disadvantage of internal insulation may be relevant for cold bridges in massive or masonry constructions but in timber constructions, cold bridges do not present a problem. The reduction of thermal mass on the inner face of external walls can be compensated for by providing corresponding mass in the floors, ceilings and internal walls. Internal insulation also means that rooms heat up more quickly and that walls are warm to the touch, making it possible to reduce the indoor room temperature, especially where radiative heating systems are used. A lower indoor heating temperature reduces energy demand and also reduces the temperature difference between inside and outside, resulting in further energy savings. One degree less temperature difference can reduce energy consumption by a few percent. The insulation is arranged between the timber posts which should be deep enough to accommodate it (see House J, for example). The inner face of the wall, once fully dry, can be clad with all kinds of wall linings, from plasterboard, to clay panel or clay plaster on a suitable plaster base. Light earth applied to batten lathwork can also be used to line the internal face of walls, using a technique similar to that used for the outside wall.



Figs. 3-6 Haus J, Darmstadt. 3: Completed building after a construction period of six months: the shell of heavy straw light earth is coated with a lime render. 4: The continuous earth shell enveloping the house took approximately four weeks to dry out. 5: Timber structure with a lattice of battens onto which the light earth is applied. The roof protected earth construction works from the weather. 6: Preparation of clay slurry from dry earth with a Knauf PFT G4 mixing machine.



Thin light internal earth wall linings on lathwork

A supporting lathwork of thin battens (12 x 24 mm) is mounted at intervals of approximately 8 cm (i.e. 12 laths/m²). If such thin laths are not available from a supplier, a sawmill can cut them cheaply.

a) If the external wall is to be given a layer of internal insulation, for example of wood or hemp fibreboard, this should be inserted between the vertical timber posts to lie flush with the internal face of the wall. If mounting on masonry, the timber laths are screwed to the wall. The light earth mixture is thrown or trowelled onto the wall and smoothed over. To achieve a level surface of even thickness, vertical laths can be temporarily fixed at intervals to the lathwork to act as runners for a board used to flatten the wall surface. The overall thickness of 25 mm and the properties of the wall face (strength, surface warmth and acoustics) corresponds to that of a clay building board.

b) If insulation is to be inserted into the cavity behind a wall cladding, the light earth mixture can be woven in S- or U-shaped manner over the laths to create a 3–4 cm thick inner skin before blowing in cavity insulation once the structure is dry. The inner face can also be achieved with a tightly-spaced lathwork onto which the material is applied like a plaster. This method is also suitable for cladding roof inclines or the underside of ceilings (Figure 9).

Once dry, the surface is roughened with a scratching float to cause the straw fibres to stick out providing a good mechanical key for a later coat of lime plaster. Alternatively the surfaces can be plastered with a thin (fibrous) coat of clay plaster to smooth over any irregularities. The final fine-finish topcoat can be a clay or lime plaster.

Mixing light earth for wet insertion

As historical straw-clays of good quality with a high fibre content show, a suitable material can be achieved with very lean earth mixes (cohesive strength 50–80 g/cm²). Ideal for such cases is a sand-free earth (e.g. from loess soil) that can be easily worked, ideally in dry form. For the fibres, soft straw, barley, oats or rye are all suitable, as is coarse hay. Straw from straw bales does not need to be chopped, only loosened. Fine layers of light earth can be made with chopped straw or similar finer fibres. The light earth mixture should comprise as much fibrous content as possible. The addition of sand, as is common with clay plaster

mortars, is not only unnecessary but also counter-productive as it leans the earth making it less able to stick to the straw fibres. Light earth mixtures with a sufficiently high straw content are not susceptible to cracking. Test blocks can be prepared to attain the desired dry bulk density of approx. 1000 kg/m³. As with other light earths, the material is prepared by either dipping the straw in clay slurry or spraying the straw with slurry. Compulsory mixers and plastering machines (with pump and compressed air) can be helpful in preparing and transporting the slurry to the required location on site (figure 6). The slurry should be made more viscous than runny, if necessary with the help of a liquifying agent, and the prepared slurry should be allowed to stand sufficiently for it to be easily workable.

Light clay undercoat plasters

Light clay undercoat plasters can be prepared as described above using bale straw, and can be applied to all kinds of substrates – earth walls, masonry, old plaster – either with a trowel or thrown and smoothed flat with a float. The mixture is also suitable for plastering straw bales or rammed earth wall surfaces. The fibres reinforce the plaster mass obviating the need for separate plaster reinforcement over timber elements or varying substrates. A plaster base is likewise unnecessary. Where ceiling beams are to be plastered, a first coat can be held in place with nailed-on thin battens, which are then embedded in a second coat. Light clay undercoat plaster can be applied in a single coat (or in successive layers with

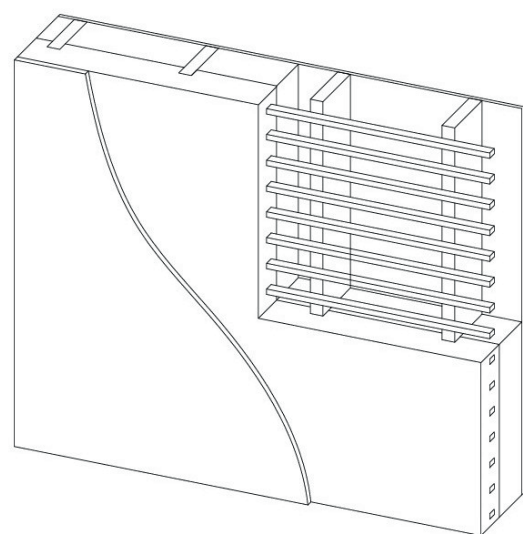

Fig. 7 Haus J, structure of external wall. From outside to inside: External lime render, straw light earth on battens (12 cm spacing), structural timber frame, studs 6x18 cm, cellulose blow-in insulation, stiffening gypsum fibreboard



Fig. 8 Haus J, shell of construction seen from inside. Once dry, internal plasterboard is applied and the cavity filled with cellulose blow-in insulation. The internal walls are filled with dry-stacked earth bricks, i.e. without mortar.

drying in-between) of between 5 and 50 mm thick, which is sufficient to level out irregularities and holes in the substrate. The resulting surface is roughened and, once dry, plastered over with a fine clay or lime plaster (figure 11).

Project examples

Haus J, Darmstadt, Architects: Schauer + Volhard

The project needed to be realised within a short time span and with a limited budget. A simple construction was designed made of timber panel elements and solid-timber ceiling elements that was erected and roofed over within a few days, so that the work continue beneath protected from the weather. The internal walls are filled with dry-stacked extruded earth bricks. The external walls were enveloped in a continuous external skin of dense light earth, mounted onto a lathwork of larch battens (24 x 30 mm) spaced 12 cm apart. The clay slurry was prepared with a plastering machine and transported via a pump within the house where it was spray-mixed with bale straw. The

light earth mixture was applied from inside to the lathwork and pressed against a formwork panel fixed to the outer face with distancing blocks that could be shifted as required. This ensured an even surface for the lime plaster.

The 12 cm external skin is relatively thin but heavy and encloses the space inside, acting as thermal store and buffer, and as sound and fire insulation. Last but not least it provides an excellent base for the lime facing plaster. Once the skin was dry, the space between the vertical posts was filled with blow-in cellulose cavity insulation and the wall clad within with plasterboard, that adds a certain stiffening function (figures 3–8). In contrast to conventional, externally insulated walls, the light earth skin can absorb the warmth of the sun, helped by the dark colour of the façade. In winter the internal insulation ensures that the walls remain warm while in summer the 35 tonnes of thermal mass in the ceilings and internal walls ensures the interior remains pleasantly cool. The overall wall thickness is 29 cm and construction took 6 months.

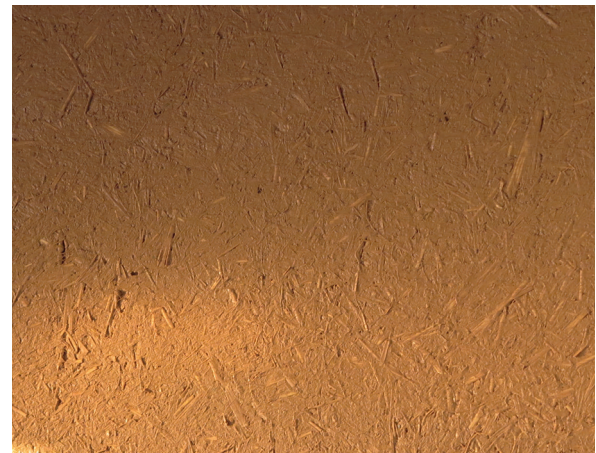

Figs. 9-12 Haus C, Groß Gerau, D

Haus C, Groß Gerau,

Architects: Schauer + Volhard

The internal surfaces of an old, predominantly brick house with a later extension was clad throughout with an insulating coat of light earth which was plastered with a thin coat of lime plaster and white-washed. The external walls were lined with 60 cm of wood fibreboard internal insulation, inserted between supporting battens and then covered with a manually-applied 25 mm thick light earth skin on thin lathwork. The roof inclines, collar beams, knee walls and ceilings were likewise clad with a lining of approx. 35 mm thick light earth wound around the battens and the cavities behind filled with blow-in cellulose cavity insulation. Openings were left as vents to facilitate quicker drying.

All the masonry surfaces were coated internally with straw light earth. The extremely uneven wall surfaces, with patches of old plaster and sections of exposed masonry, were covered in a single coat of between 10 and 25 mm thick straw light earth to create an even surface for a later thin coat of lime plaster.

The malleable mass of light earth was made of a lean earth and bale straw, mixed manually by dipping in clay slurry. The light earth was applied by hand and smoothed flat with a wooden float. The bulk density of the light earth corresponds to 1000 kg/m^3 . The entire building work was conducted by the family themselves together with a team of architecture students under instruction, in order to stay within an extremely limited budget (figures 9–12).

Fig. 9 Insulating wall lining of external walls: straw light earth is thrown or trowelled onto a latticework of thin laths and levelled with a board drawn over vertical runners of temporarily-mounted thin plaster laths. Cladding of the roof incline with straw light earth on latticework.

Fig. 10 Thin knee wall, 4 cm thick.

Fig. 11 Roughened surface of the internal insulating wall, ceiling and roof lining. The light earth plaster can also be applied over old masonry and plaster, providing an even surface for the subsequent finishing coat of lime plaster.

Fig. 12 Light earth undercoat, worked smooth with a float.

References

- Volhard, Franz: Bauen mit Leichtlehm – Handbuch für das Bauen mit Holz und Lehm. 8. überarbeitete und erweiterte Auflage, Birkhäuser Verlag, Basel 2016; 312 Seiten, 525 Abbildungen; ISBN 978-3-0356-0619-5
www.degruyter.com/view/product/457066
- Volhard, Franz: Light earth building–A Handbook for Building with Wood and Earth. 8th revised and expanded edition, Birkhäuser Verlag, Basel 2016; Translation Julian Reisenberger; 312 pages, 525 illustrations; ISBN 978-3-0356-0634-8
www.degruyter.com/view/product/457068
- Volhard, Franz: Construire en Terre Allégée. *Éditions Actes Sud, Arles 2016*; Traduction Aymone Nicolas; 288 pages, 440 illustrations; ISBN 978-2-330-05050-4
www.actes-sud.fr/catalogue/architecture-eturbanisme/construire-en-terre-allegee
- Volhard, Franz: Lehmausfachungen und Lehmputze – Untersuchungen historischer Strohlehme. Fraunhofer IRB Verlag, Stuttgart 2010; 120 Seiten, 181 Abbildungen; ISBN 978-3-8167-8119-6
- Volhard, Franz: Strohlehm als Außenschale im Holzbau. In: Dachverband Lehm e.V. (Hrsg.): Lehm 2012 – Tagungsbeiträge der 6. Internationalen Fachtagung für Lehm-bau. Weimar 2012, S. 296-299
- Lehmbau Regeln: Begriffe – Baustoffe – Bauteile. Dachverband Lehm e.V. (Hrsg.); Vieweg+Teubner Verlag Wiesbaden 1999, 3. Aufl. 2009; 120 Seiten mit Abbildungen; ISBN 978-3-8348-0189-0
- FAL e.V. (Hrsg.): Impulse für den Lehmbau – Zeitgemäßes Bauen mit Holz und Lehm; Inspirations for Earth Building – Contemporary Building with Wood and Earth. Franz Volhard – Architekt und Forscher – Schauer + Volhard Architekten. Schriftenreihe Lehm-museum Gnevsdorf Band 3, Ganzlin; 48 Seiten, Deutsch-Englisch, 7 EUR+Porto. Bestellung bei: info@fal-ev.de